

Digital Pulse Processor

APV8516-14 (500Mps, 16 channels, 14-bit)

MADE IN JAPAN

VME

20190916



Features

- ADC 500 Mps, 16 channels, Resolution: 14-bit
- Time resolution Coarse: 2 ns | Fine: 7.8 ps , LSB
- Throughput 1Mcps and more / channel
- Analyze more List(TDC+QDC), Wave, Histogram, List-Wave*1
- Functions (digital)CFD, TDC, QDC, PSA*1, coincidence*1
- Communication I/F TCP/IP, Gigabit ethernet
- Usage example Data transfer: 10MByte (Gigabit) / second more
Multi channel system using plastic scintillator
Multi channel system using scintillators and wire chamber etc.

*1 Addition of options, specification change is possible.

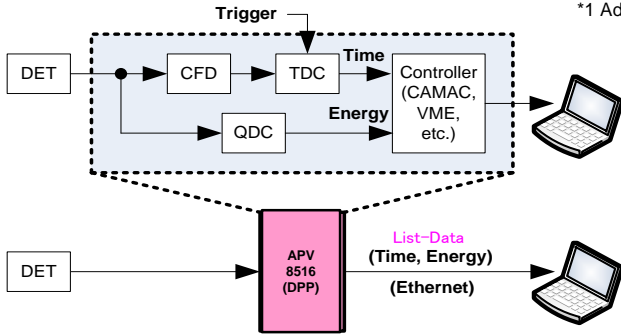

List data example

	80	15	11	0
Event#1	TDC[63..0]	CH[3..0]	QDC[11..0]	
Event#2	TDC[63..0]	CH[3..0]	QDC[11..0]	
Event#N	TDC[63..0]	CH[3..0]	QDC[11..0]	

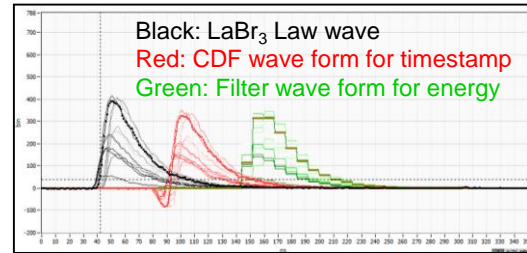

Wave mode: LaBr₃ detector used

Usage example using multi board

List mode measurement

List-Com mode measurement



Connect Sync-CLR of board #0 to other Sync-CLR-I

NIM-CLR or Fast-Signal



Repeated CLR is entered, and when measuring the time difference spectrum from T₀, input CLR to CH 1 of each board. Use a fast rise signal such as NIM.

* Option

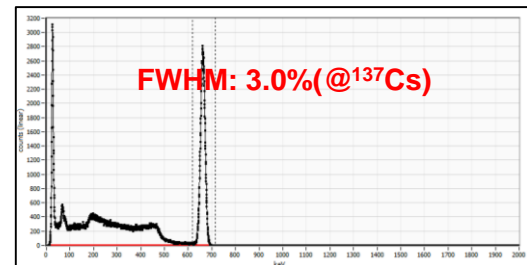

Energy Spectrum: LaBr₃ detector used

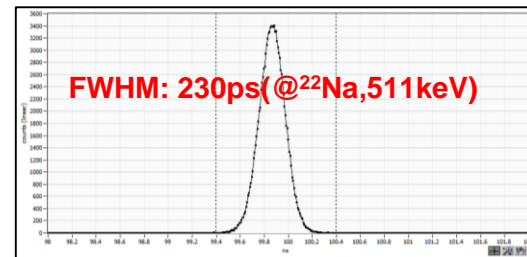

Time Spectrum:
LaBr₃ detector vs LaBr₃ detector

*Custom order, custom firmware production available.

*Please note that contents may change without prior notice.

[Website](#)

Manufacture of Radiation and Radioactivity measurement devices

TechnoAP Co., Ltd.

2976-15 Mawatari, Hitachinaka-shi, Ibaraki, 312-0012, Japan

+81-29-350-8011

+81-29-352-9013

order@techno-ap.com

